

# Electro-Mechanical Single Head Machines

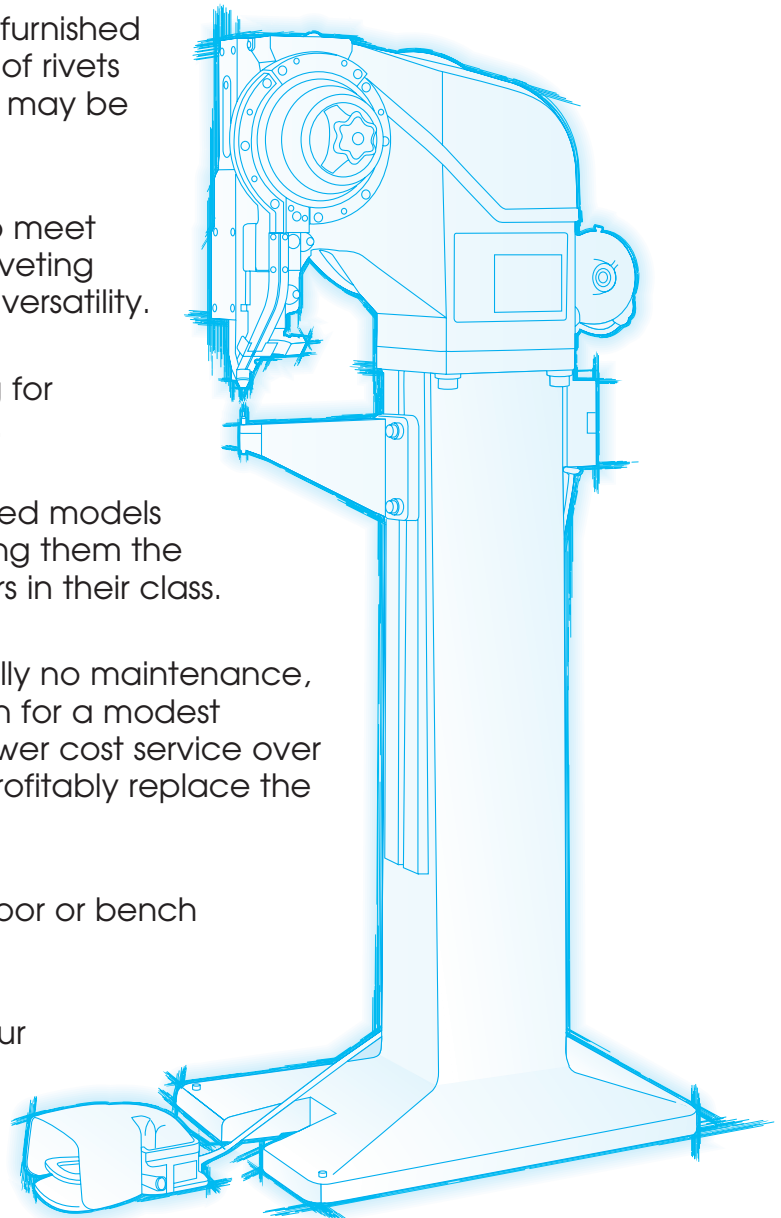

National's Electro-Mechanical Single Head Machines were designed to update riveting techniques and meet the requirements of a wide range of fastening applications. Proven to increase production while saving time and money, these designs are now incorporated into all National Rivet setters.

- ↑ These models have an electric motor driven flywheel with a crankshaft and connecting rod powering a toggle link mechanism. With this type of drive, when the toggle links straighten out, full power is delivered to the rivet and a consistent riveted height is maintained. Riveting cycle time is 1/3 second.
- ↑ Additional hopper assemblies can be furnished to allow one machine to set a variety of rivets within its capacity. Hopper assemblies may be changed easily in a few minutes.
- ↑ Special anvil arms can be provided to meet the requirements of a wide range of riveting applications, allowing for exceptional versatility.
- ↑ All models feature complete guarding for the highest degree of operator safety.
- ↑ Like all National machines, these rugged models are made with steel weldments, making them the strongest and most durable rivet setters in their class.
- ↑ With their long machine life and virtually no maintenance, these riveters give you high production for a modest investment and provide you better, lower cost service over a greater number of years. They will profitably replace the outdated units in your shop.
- ↑ Some models are available in either floor or bench mount versions.
- ↑ Each model can be customized to your specific needs and requirements.





# 800-816 Electro Mechanical



Model 800



Model 816

## Model 800 Specifications

<b>Rivet Capacity</b>	.25" dia. x 1.375" length
<b>Throat Depth</b>	12"
<b>Stroke</b>	2.375" Std., 1.875 or 3.375" avail.
<b>Hopper</b>	Rotary
<b>Cycle Time</b>	1/3 second
<b>Upset Force</b>	5500#
<b>Power</b>	Electric: 1/2 H.P., 1140 R.P.M., 60 cy., 1 ph., 115v Std. Opt.: 220/440/480v, 3 ph., 60 cy.
<b>Weight</b>	725#
<b>Floor Space</b>	H: 66-5/8" W: 24" D: 35"

## Model 816 Specifications

<b>Rivet Capacity</b>	.25" dia. x 1.375" length
<b>Throat Depth</b>	16"
<b>Stroke</b>	2.375" Std., 1.875 or 3.375" avail.
<b>Hopper</b>	Rotary
<b>Cycle Time</b>	1/3 second
<b>Upset Force</b>	5500#
<b>Power</b>	Electric: 1/2 H.P., 1140 R.P.M., 60 cy., 1 ph., 115v Std. Opt.: 220/440/480v, 3 ph., 60 cy.
<b>Weight</b>	760#
<b>Floor Space</b>	H: 66-5/8" W: 24" D: 38"