

FOR AUTOMATIC FEED RIVET MACHINES

This work sheet is designed to help you order the anvils you need.

1. Select the anvil type, 1 through 5.
2. Fill in the dimensions "A" through "F".
3. Indicate the part number (if any) of the anvil you are trying to duplicate.
4. Indicate the rivet part number or dimensions and type of rivet (tubular, solid or split).
5. Indicate type of clinch you would like the anvil to produce on your rivet (roll, star or solid).
6. FAX or mail us a copy of this sheet and we will respond with a quote.

TYPE	"A"	"B"	"C"	"D"	"E"	"F"	CURRENT ANVIL NUMBER	RIVET PART NUMBER OR DIMENSIONS	RIVET TYPE	CLINCH TYPE

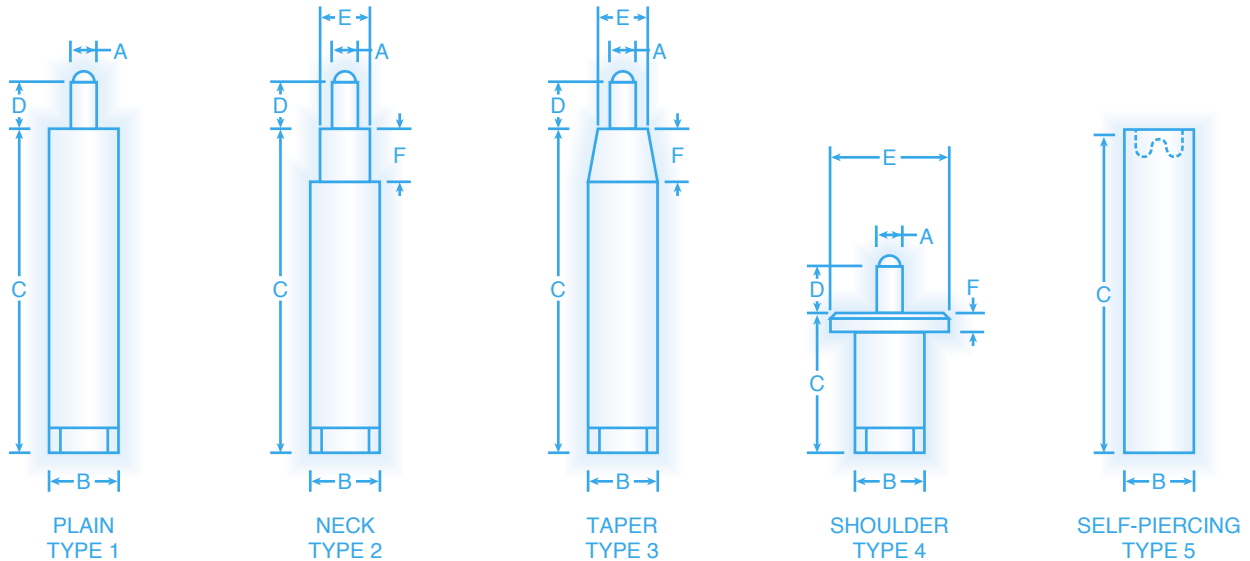

For a free quotation, mail or fax this sheet to:

National Rivet

21 East Jefferson Street • P.O. Box 471 • Waupun, WI 53963
 Phone 920-324-5511 • FAX: 920-324-3388
 Toll Free: 888-324-5511

Send e-mail to: mail@natriv.com. • Home Page: www.natriv.com