

Internally Threaded Inserts

Internally threaded fasteners are tubular rivets with internal threads available for screw attachments. These fasteners are available in most styles and materials.

Blind Clinch Nut

This style fastener can be installed from one side of the work piece. A pull-up stud engages the thread and exerts a pull causing the shank to expand firmly against the material being fastened.

THREAD SIZE	DIAMETER	A	B	WORK HOLE
4 - 40 UNC-2B	.151/.155	.255/.285	.022/.028	.155/.157
6 - 32 UNC-2B	.185/.189	.310/.340	.028/.036	.189/.193
8 - 32 UNC-2B	.217/.221	.342/.372	.028/.036	.221/.226
10 - 24 UNC-2B	.246/.250	.391/.421	.034/.042	.250/.256
10 - 32 UNF-2B	.246/.250	.391/.421	.034/.042	.250/.256
1/4 - 20 UNC-2B	.328/.332	.460/.490	.054/.062	.332/.338

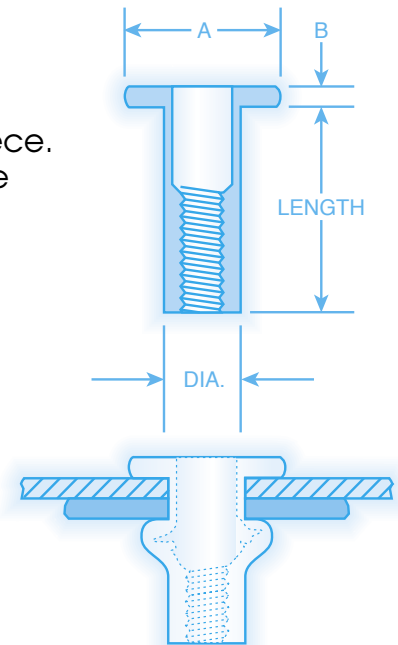

Clinch Nut

This style of fastener is designed for use with standard automatic rivet setting machines. When both sides of the work piece are accessible a clinch nut provides economical thread installation.

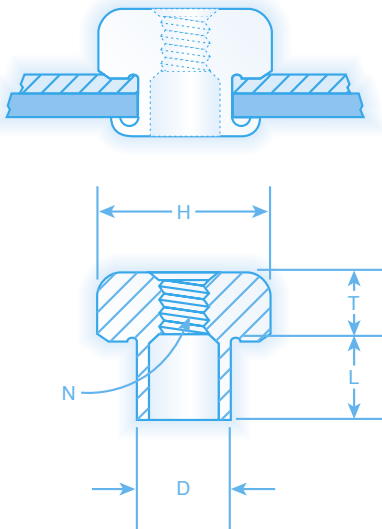

NUT SIZE (Thread)	HEAD		APPROX. NO. OF THREADS	SHANK DIAMETER	WORK HOLE DIAMETER	SHANK LENGTHS
	DIAMETER	THICKNESS				
	H	T	N	D		L
3 - 48	9/32	5/64	4	.155/.160	.171	AS SPECIFIED
4 - 40	5/16	3/32	4	.155/.160	.171	
5 - 40	11/32	7/64	4-1/2	.186/.191	.203	
6 - 32	11/32	7/64	4	.186/.191	.203	
8 - 32	3/8	1/8	4	.218/.223	.234	
10 - 24	13/32	1/8	3-1/2	.249/.254	.265	
10 - 32	13/32	1/8	4	.249/.254	.265	
1/4 - 20	15/32	3/16	3-1/2	.328/.335	.343	